



Flow-Tek®

A Subsidiary of BRAY INTERNATIONAL, Inc.

3 Piece Ball Valves

Model FP - Full Port: 1/4" - 4"

Model SP - Standard Port: 3/4" - 2 1/2"



Triad Series

Flow-Tek's Triad Series ball valves feature live loaded stem seals and a redundant body seal design. Available in full and standard port models, these rugged, high pressure 3-piece valves are ideal for process, severe service, high temperature, and high cycle applications.

Fire Safe - Certified to API 607 4th Edition Triad Series valves have been fire tested and meet or exceed these standards.

Secure Mount Triad Series valves offer ease of automation due to an integrally cast actuator mounting pad that complies with ISO 5211 standards through 2" valve sizes.

Pressure Ratings

Models FP & SP: 2200 psi WOG

End Connections

- Threaded
- Socket Weld
- Butt Weld
- Extended Socket Weld
- Extended Butt Weld
- ASME 150/300/600 Flanged
- Custom
- Grooved

Body Bolts (A) As standard Triad Series valves feature hex head bolts to join end connections to the tapped valve center section. This design, in lieu of a through bolt design, ensures precise alignment of the end caps – minimizing potential problems such as bolt shrinkage and elongation in severe temperature and thermal cycling applications. Less bolting movement reduces the chance for body seal failure.

Ball (B) Flow-Tek balls are precision machined and mirror finished for bubble-tight shut off with less operating torque. Ball edges have machined curvatures to reduce seat wear and provide a high cycle life. As an added safety feature, a hole in the stem slot of each ball equalizes pressure between the body cavity and the line media flow.

Body (C) Valve bodies are investment cast and solution annealed/normalized for the highest quality and added strength. Stainless Steel bodies and end caps are passivated. Carbon Steel bodies are phosphate coated for increased corrosion resistance. All body castings are marked with a foundry heat number for full traceability to ASTM standards.

Seat (D) Flow-Tek's seat design ensures bi-directional, bubble-tight sealing while providing the lowest possible torque. Resilient seats feature relief slots or O.D. clearance to relieve pressure past the upstream seat. This design reduces friction, minimizes seat wear and lowers operating torque.

End Connections (E) The Triad Series is available with threaded, socket weld, butt weld, extended socket weld and butt-weld, ASME 600 flanged or custom connections.

Double Lock Nut Design (F) Double lock nuts allow handles to be easily and safely removed while the valve is under full line pressure.

Live-Loaded Stem Seals (G) The live-loaded seals considerably increase the number of cycles between maintenance adjustments.

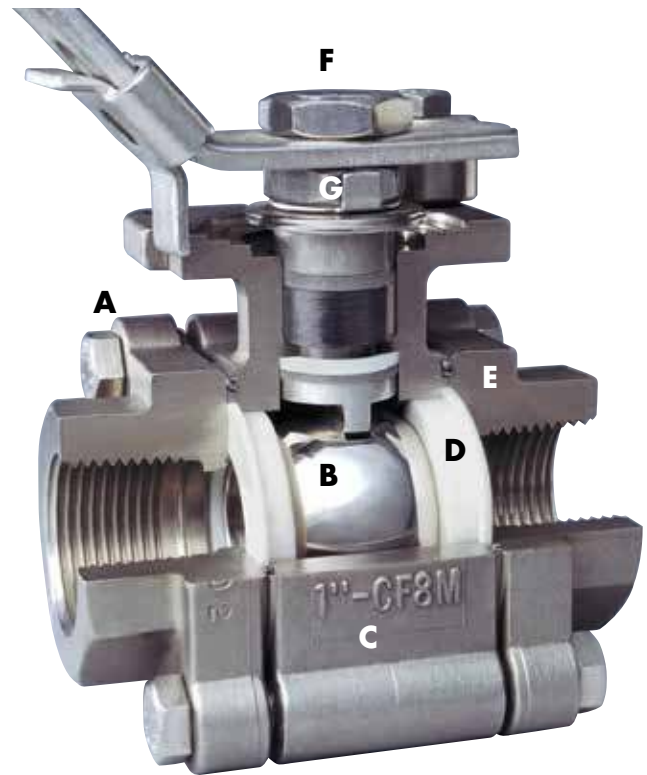
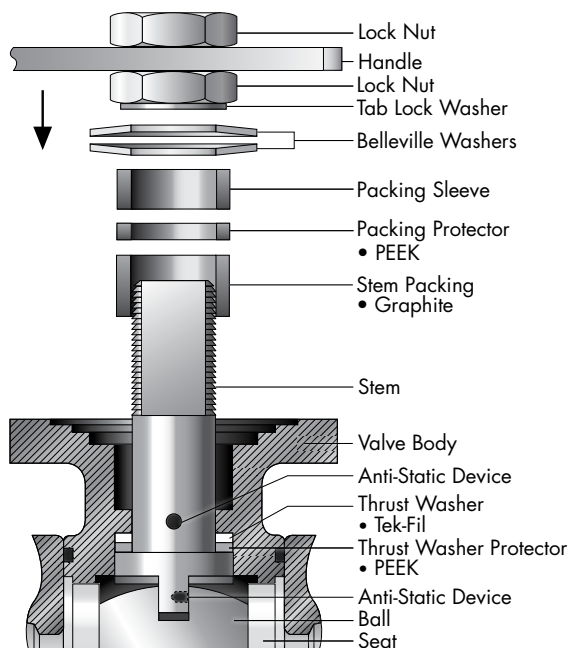

ASME B16.34 Class 600

All Triad Series valves are designed to meet this specification and can be certified upon request at order submittal.

Smart Stem Assemblies

Flow-Tek manufactures heavy duty, high quality stems with double "D" connection to ball and operator mounting. All Flow-Tek stems are internal entry and blowout proof for maximum safety. Triad Series valves through 2 1/2" feature strong, large diameter stems with live-loaded, self-adjusting primary and secondary sealing. Utilizing bellville washers, the stem seal automatically adjusts to compensate for changes in temperature and normal wear. The assembly is secured by a saddle-type lock washer, preventing unthreading of stem nuts in high cycle automation applications.

Stem Seals The Thrust Washer of 50% Stainless Steel /50% PTFE and the Thrust Washer Protector of PEEK combine to provide the primary seal. An adjustable Stem Packing and an additional PEEK Packing Protector create a multiple secondary seal between the stem and body. The stem packing is composed of graphite providing fire safe protection and a very high cycle life. This dual stem seal arrangement is a Flow-Tek exclusive.

Anti-Static Protection Triad Series valves feature anti-static grounding devices as standard. These devices ensure electrical continuity between valve ball, stem and body, eliminating the possibility of static electrical charges creating sparks within the valve.

Dual Body Seals

Flow-Tek's Triad Series valves utilize a dual body seal system to provide added protection against external leakage. The inner primary seal is TFM material. The secondary seal is graphite. Utilizing TFM as the inner seal minimizes the possibility of color contamination of the process media. Both body seals are securely retained in grooves machined into the body. These grooves reduce seal movement and cold flow. Therefore, constant compression is maintained even under extreme conditions.

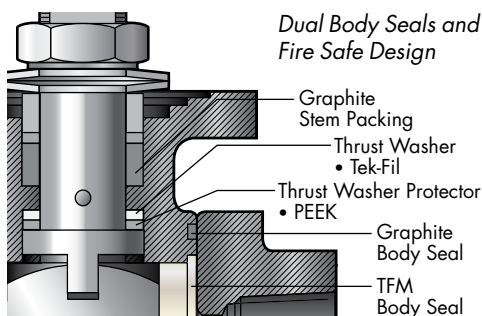

Fire Safe: API 607-4 Certified

Flow-Tek's dual body seals, Smart Stem with graphite stem packing, and metal-to-metal contact of ball to body combine to produce a valve that meets the highest fire safety standards under extreme conditions. In the event of a fire, if excess heat destroys the resilient seat materials, the metal ball makes contact with the metal body. Graphite secondary body seals prevent external leakage, and the live-loaded graphite stem packing prevents stem leakage.

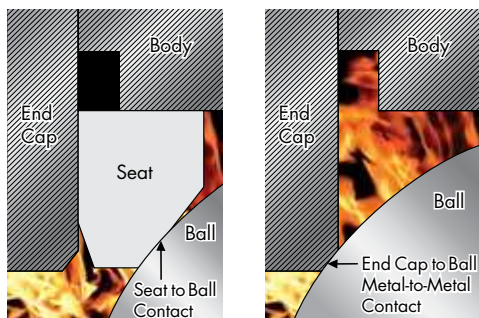

Pre-Burn

Post-Burn

Secure Mount A unique standard feature of the Triad Series is an integrally cast top flange that ensures positive actuator mounting. This actuator mounting pad eliminates unwanted actuator movement during high cycle or continuous duty applications. Actuation equipment can be easily and safely removed while the valve is under full line pressure. The actuator mounting pad is in compliance with ISO 5211 bolting pattern standards.

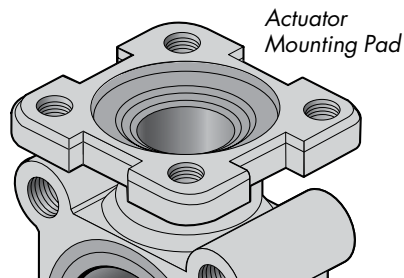

Automated Valves



Additionally, the mounting pad allows for ease of field assembly of Flow-Tek's Media Containment Unit. This unit, combined with the double body seals, makes this the ideal valve for emissions free severe service, elevated and semi-cryogenic temperatures and high cycle applications.

Flow-Tek handles feature a Safety Trigger to prevent accidental movement of ball position. The trigger locks the handle in the open or closed position. The handle lock can be bypassed, if needed, with a small bolt through the handle in the release position.

Manual Operated Valves

A **Padlock (A)** can be added to secure the handle in position, preventing unwanted access. A **Travel Stop (B)** limits the movement of handle to set 90° intervals, preventing over travel of the ball.

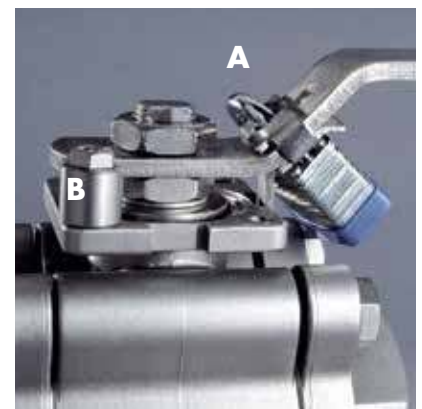

Seat Selection

A wide range of seat materials are available to meet most applications. The standard seat is TFM 1600 – offering the exceptional chemical resistance of PTFE plus lower porosity and permeability, improved temperature range and reduced valve torques. Options include RPTFE, Stainless Steel/PTFE (50/50), UHMWPE, Virgin PTFE, PEEK, Tek-Fil® (carbon/graphite filled TFM), full metal seats and Cavity Fillers. PEEK seats offer high pressure/temperature capability. Tek-Fil seats offer reduced torque in high temperature, high cycle, and steam service applications.

Item	Name	Stainless Steel	Carbon Steel	Qty.
1	Body	ASTM A351 Gr CF8M	ASTM A216 Gr WCB	1
2	End Cap*	ASTM A351 Gr CF8M*	ASTM A216 Gr WCB	2
3	Ball	ASTM A351 Gr CF8M	ASTM A351 Gr CF8M	1
4	Seat	TFM	TFM	2
5	Stem	ASTM A479 Type316	ASTM A479 Type316	1
6A	Body Seal	TFM	TFM	2
6B	Body Seal	Graphite	Graphite	2
9	Body Bolt*	ASTM A193 B8	ASTM A193 B8	8
10	Anti-Static Device	SS316	SS316	2
11A	Packing Protector	PEEK	PEEK	1
11B	Thrust Washer Protector	PEEK	PEEK	1
12	Thrust Washer	Tek-Fil	Tek-Fil	1
14	Stem Packing	Graphite	Graphite	1
15	Packing Gland Sleeve	SS304	SS304	1
18	Belleville Washer	SS301	SS301	2
19	Tab Lock Washer	SS300	SS300	1
23	Travel Stop Set Sleeve	SS304	SS304	1
24	Travel Stop Bolt	SS300	SS300	1
25	Handle	SS304	SS304	1
26	Lock Nut	SS304	SS304	2
28	Handle Sleeve	Vinyl	Vinyl	1
29	Locking Device	SS304	SS304	1

*Weld Ends use CF3M.

*All Fine Thread in sizes 1/4" through 2 1/2"

1/2 for 2" FP and 2 1/2" SP.

Components & Materials

Valve Sizes:

1/4" through 2 1/2"

Valve Models:

- FP - Full Port
- SP - Standard Port

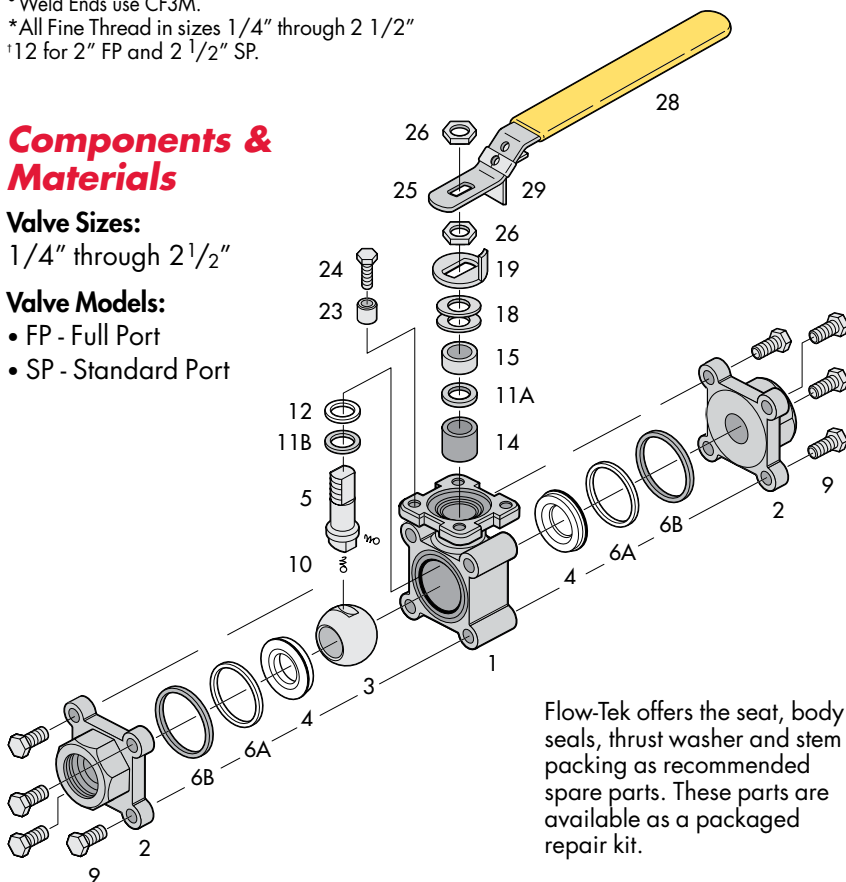

Flow-Tek offers the seat, body seals, thrust washer and stem packing as recommended spare parts. These parts are available as a packaged repair kit.

Valve Sizes 1/4" through 4"

Threaded End Connections meet

ASME B1.20.1 NPT.

Socket Weld End Connections meet

ASME B16.11.

Butt Weld End Connections meet

ASME B16.25.

Flanged End Connections meet

ASME Class 600,

ASME B16.10 and B16.5.

- All Triad Series valves are designed to meet ASME B16.34 Class 600 specifications and can be certified as such upon request at order submittal.
- All valves are Fire Safe and certified to API 607 4th Edition.
- Valves meet NACE MR0175.
- Valve body and end connections are high quality investment cast and solution annealed/normalized.
- All valves are hydrostatically shell tested to 1.5 x rating.
- All valves 100% air seat tested under water at 80–100 psi.

End Connections:

- Threaded
- Socket Weld
- Butt Weld
- Extended Socket Weld
- Extended Butt Weld
- ASME 150/300/600 Flanged
- Custom

Pressure Ratings

Threaded, Socket Weld and Butt Weld:

Model FP/SP 2200 psi WOG

Flanged: per flange rating, consult factory

Steam Service:

Valve Size ins	TFM Seats		Tek-Fil Seats		Peek Seats	
	PSIG (WSP)	°F	PSIG (WSP)	°F	PSIG (WSP)	°F
1/4 - 1	150	365	425	455	500	470
1 1/4 - 1 1/2	150	365	350	435	500	470
2 - 4	150	365	300	421	500	470

UHMWPE seats are not recommended for steam.

Vacuum Service: To 29 inches Hg. gauge.

Pressure / Temperature

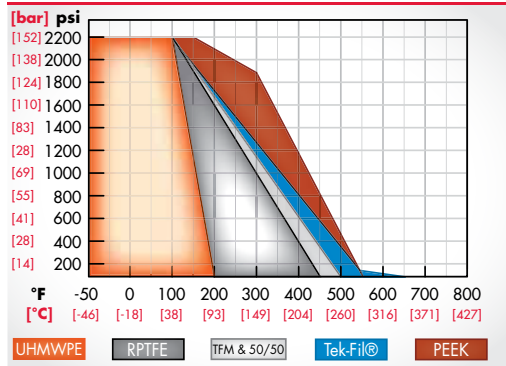

Note: Carbon Steel valves are limited to -20° F.

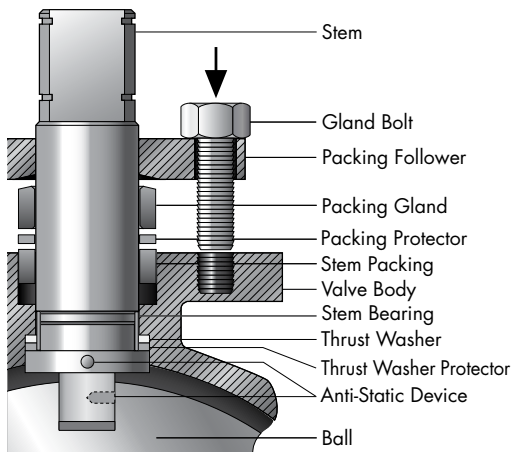

Stem Design for 3" & 4" Valves

The stem is guided by the valve body and the gland, ensuring smooth operation even in high torque service. The packing gland is adjustable and all stems are polished to reduce torque. Optional Belleville washers can be added for a self-adjusting, live load.

Item	Name	Stainless Steel	Carbon Steel	Qty.
1	Body	ASTM A351 Gr CF8M	ASTM A216 Gr WCB	1
2	End Cap*	ASTM A351 Gr CF8M*	ASTM A216 Gr WCB	2
3	Ball	ASTM A351 Gr CF8M	ASTM A351 Gr CF8M	1
4	Seat	TFM	TFM	2
5	Stem	ASTM A479 Type316	ASTM A479 Type316	1
6A	Body Seal	TFM	TFM	2
6B	Body Seal	Graphite	Graphite	2
7	Seat Support	ASTM A479 Type316	ASTM A479 Type316	2
9	Body Bolt*	ASTM A193 B8	ASTM A193 B8	16 †
10	Anti-Static Device	SS316	SS316	2
11A	Packing Protector	PEEK	PEEK	1
11B	Thrust Washer Protector	PEEK	PEEK	1
12	Thrust Washer	Tek-Fil	Tek-Fil	1
13	Stem Bearing	RPTFE	RPTFE	1
14	Stem Packing	Graphite	Graphite	1
15	Packing Gland	SS304	Carbon Steel	1
16	Packing Follower	ASTM A351 Gr CF8M	ASTM A216 Gr WCB	1
17	Gland Bolt	SS304	Carbon Steel	2
20	Stop Housing	ASTM A351 Gr CF8M	ASTM A216 Gr WCB	1
21	Housing Bolt	SS304	Carbon Steel	4
22	Travel Stop	SS304	Carbon Steel, Zinc Plated	1
25A	Handle	Carbon Steel	Carbon Steel	1
25B	Handle Junction	Ductile Iron	Ductile Iron	1
27	Handle Bolt	Carbon Steel	Carbon Steel	2
30	Snap Ring	Carbon Steel, Nickel Plated	Carbon Steel, Nickel Plated	1

*Weld Ends use CF3M.

*All Course Thread in sizes 3" and 4"

†16 for 3" and 24 for 4"

Components & Materials

Valve Sizes:

3" and 4"

Valve Models:

- FP - Full Port

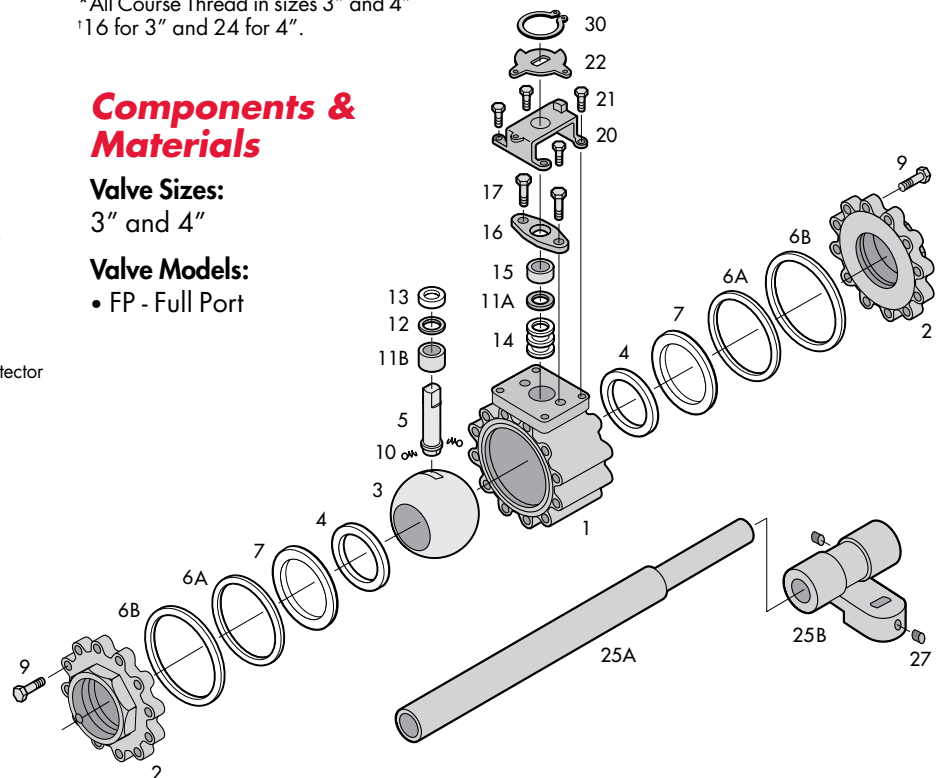

FULL PORT Model FP

Size ins mm	A1 Threaded, Socket, Butt W	A2 Extended Butt Weld	A3 Extended Socket Weld	A4 Cl. 600 Flanged	øB	C	C1	D	E1	E2	F1	F2	F3	G	G1	G2	H1	H2	C _V	Torque lbs-in Nm	Weight lbs. kg.
1/4	2.99	8.98	9.98	—	0.46	2.83	1.45	6.50	0.55	0.30	1.10	0.54	1.10	1.01	4.50	—	0.63	0.50	8	70	2.3
8	76	228	253.4	—	11.6	72	36.9	165	14	7.6	28	13.72	28	25.6	114.3	—	16	12.7	8	7.9	1
3/8	2.99	8.98	9.98	—	0.50	2.83	1.45	6.50	0.69	0.42	1.10	0.68	1.10	1.01	4.50	—	0.63	0.50	8	70	2.3
10	76	228	253.4	—	12.7	72	36.9	165	17.5	10.7	28	17.15	28	25.6	114.3	—	16	12.7	8	7.9	1
1/2	2.99	8.98	9.98	6.50	0.56	2.83	1.45	6.50	0.85	0.55	1.26	0.84	1.18	1.01	4.50	2.76	0.71	0.50	30	70	2.3
15	76	228	253.4	165.1	14.2	72	36.9	165	21.7	14	32	21.34	29.92	25.6	114.3	70.2	18	12.7	30	7.9	1
3/4	3.31	9.24	10.37	7.50	0.81	3.03	1.63	6.50	1.07	0.74	1.50	1.05	1.41	1.03	4.56	3.13	0.73	0.56	55	130	3.4
20	84	234.7	263.3	190.5	20.5	77	41.5	165	27.1	18.8	38	26.67	35.74	26.25	115.9	79.5	18.5	14.3	55	14.7	1.54
1	3.94	9.62	10.87	8.50	1.00	3.82	2.18	9.84	1.33	0.96	1.89	1.31	1.73	1.16	4.63	3.44	0.87	0.63	105	180	6.2
25	100	244.4	276.2	215.9	25.4	97	55.3	250	33.8	24.4	48	33.4	43.96	29.4	117.5	87.4	22	15.9	105	20.3	2.81
1 1/4	4.33	9.91	11.28	9.00	1.26	4.02	2.36	9.84	1.68	1.28	2.20	1.66	2.10	1.21	4.69	3.55	0.91	0.69	200	310	8.7
32	110	251.6	286.6	228.6	32	102	60	250	42.6	32.5	56	42.16	53.36	30.8	119.1	90.1	23	17.5	200	35	3.95
1 1/2	5.04	10.22	11.72	9.50	1.50	4.29	2.68	10.43	1.91	1.5	2.48	1.90	2.36	1.41	4.75	3.64	0.96	0.75	275	415	12
40	128	259.6	297.8	241.3	38	109	68	265	48.6	38	63	48.26	59.88	35.8	120.7	92.5	24.5	19.1	275	46.9	5.44
2	5.71	10.76	12.50	11.50	2.00	4.65	3.03	10.43	2.41	1.94	2.99	2.38	2.91	1.48	4.87	4.37	1.00	0.87	500	695	17.8
50	145	273.2	317.6	292.1	50.8	118	77	265	61.1	49.3	76	60.33	73.9	37.5	123.8	111.1	25.5	22.2	500	78.5	8.07
3	7.96	12.02	16.02	14.00	3.00	7.00	3.70	15.40	3.54	2.90	4.18	3.50	4.21	1.97	6.00	4.99	1.62	0.87	1160	1585	52
80	202	305.3	406.9	355	76.5	177.1	94.5	390	89.8	73.7	106.4	88.9	107	50	153	126.7	41.2	22.2	1160	179.1	23.56
4	9.00	12.88	16.88	17.00	4.02	12.72	4.88	38.98	4.54	3.83	5.38	4.50	5.30	2.09	6.00	6.06	1.62	1.00	2117	2800	91
100	230	327.2	428.7	432	102	323	124	990	115.2	97.3	136.6	114.3	134.8	53	153	153.9	41.2	25.5	2117	316.4	41.22

Torque at maximum rated pressure, clean water, TFM seats.
Refer to Technical Bulletin 1005 for complete torque information.

Weights are based on valves with Threaded End Connections.

STANDARD PORT Model SP

Size ins mm	A1 Threaded, Socket, Butt W	A2 Extended Butt Weld	A3 Extended Socket Weld	øB	C	C1	D	E1	E2	F1	F2	F3	G	G1	H1	H2	C _V	Torque lbs-in Nm	Weight lbs. kg.
3/4	2.99	8.98	10.10	0.56	2.83	1.45	6.50	1.07	0.74	1.50	1.05	1.41	1.01	4.56	0.71	0.56	12	70	2.3
20	76	228	256.6	14.2	72	36.9	165	27.1	18.8	38	26.67	35.74	25.6	115.9	18	14.3	12	7.9	1
1	3.31	9.24	10.49	0.81	3.03	1.63	6.50	1.33	0.96	1.89	1.31	1.73	1.03	4.63	0.73	0.63	32	130	3.4
25	84	234.7	266.5	20.5	77	41.5	165	33.8	24.4	48	33.4	43.96	26.25	117.5	18.5	15.9	32	14.7	1.54
1 1/4	3.94	9.62	11.00	1.00	3.82	2.18	9.84	1.68	1.28	2.20	1.66	2.10	1.16	4.69	0.87	0.69	46	180	6.2
32	100	244.4	279.4	25.4	97	55.3	250	42.6	32.5	56	42.16	53.36	29.4	119.1	22	17.5	46	20.3	2.81
1 1/2	4.33	9.91	11.41	1.26	4.02	2.36	9.84	1.91	1.5	2.48	1.90	2.36	1.21	4.75	0.91	0.75	82	310	8.7
40	110	251.6	289.8	32	102	60	250	48.6	38	63	48.26	59.88	30.8	120.7	23	19.1	82	35	3.95
2	5.04	10.22	11.97	1.50	4.29	2.68	10.43	2.41	1.94	2.99	2.38	2.91	1.41	4.87	0.96	0.87	120	415	12
50	128	259.6	304	38	109	68	265	61.1	49.3	76	60.33	73.9	35.8	123.8	24.5	22.2	120	46.9	5.44
2 1/2	6.06	10.76	12.72	2.00	4.65	3.03	10.43	2.91	2.32	3.46	2.88	3.51	1.65	4.98	1.18	0.98	240	695	17.8
65	154	273.2	323.2	50.8	118	77	265	73.8	58.9	88	73.03	89.14	42	126.6	30	25	240	78.5	8.07

1/4" - 2 1/2"
Valves

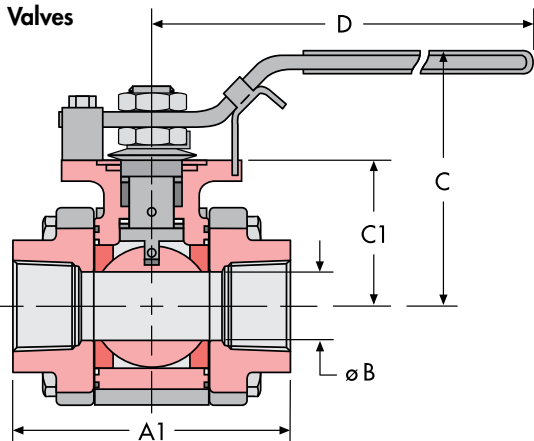

3" - 4"
Valves

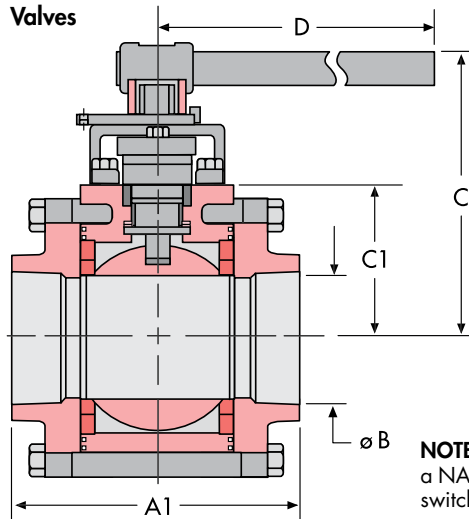

NOTE 2: 2 1/2", 3" & 4" valves feature a NAMUR stem slot for ease of limit switch mounting.

Threaded End

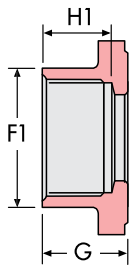

Socket Weld End

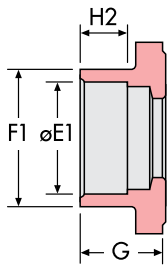

**Butt Weld End
Schedule 80**

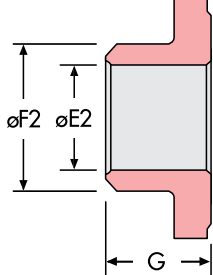

Butt Weld Ends also available in other pipe schedules

**Extended Butt Weld End
Schedule 80**

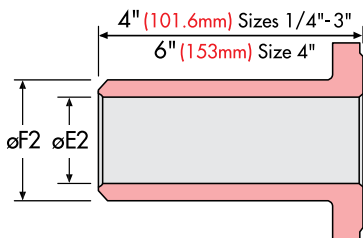

Extended Socket Weld End

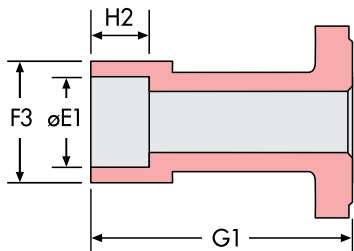

**Flanged End
Class 600 lb.**

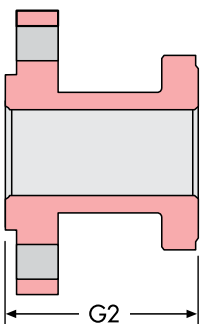

SECURE MOUNT Model FP

Size ins mm	I	J	F ₀	BC DIA.	K	L	M	øP	U UNC
1/4-1/2	1.17	1.17	F04	1.65	0.315	0.551	0.250	0.374	#10-24
8-15	29.7	29.7		42	8	14	6.35	9.5	
3/4	1.17	1.17	F04	1.65	0.315	0.551	0.250	0.374	#10-24
20	29.7	29.7		42	8	14	6.35	9.5	
1	1.95	1.95	F07	2.76	0.512	0.910	0.374	0.622	5/16-18
25	49.5	49.5		70	13	23	9.5	15.8	
1 1/4	1.95	1.95	F07	2.76	0.551	0.952	0.374	0.622	5/16-18
32	49.5	49.5		70	14	23.5	9.5	15.8	
1 1/2	1.95	1.95	F07	2.76	0.670	1.043	0.472	0.748	5/16-18
40	49.5	49.5		70	17	26.5	12	19	
2	1.95	1.95	F07	2.76	0.728	1.102	0.472	0.748	5/16-18
50	49.5	49.5		70	18.5	28	12	19	
3	3.54	1.87	—	—	1.75	3.07	0.670	1.20	1/2-13
80	90	47.6			44.4	78	17	30	
4	3.37	3.37	—	4.00	1.65	3.58	1.02	1.73	1/2-13
100	85.7	85.7		100	41.9	90.9	25.9	43.9	

SECURE MOUNT Model SP

Size ins mm	I	J	F ₀	BC DIA.	K	L	M	øP	U UNC
3/4	1.17	1.17	F04	1.65	0.315	0.551	0.250	0.374	#10-24
20	29.7	29.7		42	8	14	6.35	9.5	
1	1.17	1.17	F04	1.65	0.315	0.551	0.250	0.374	#10-24
25	29.7	29.7		42	8	14	6.35	9.5	
1 1/4	1.95	1.95	F07	2.76	0.512	0.910	0.374	0.622	5/16-18
32	49.5	49.5		70	13	23	9.5	15.8	
1 1/2	1.95	1.95	F07	2.76	0.551	0.952	0.374	0.622	5/16-18
40	49.5	49.5		70	14	23.5	9.5	15.8	
2	1.95	1.95	F07	2.76	0.670	1.043	0.472	0.748	5/16-18
50	49.5	49.5		70	17	26.5	12	19	
2 1/2	1.95	1.95	F07	2.76	0.728	1.102	0.472	0.748	5/16-18
65	49.5	49.5		70	18.5	28	12	19	

**1/4" - 2 1/2"
Valves**

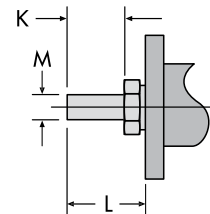
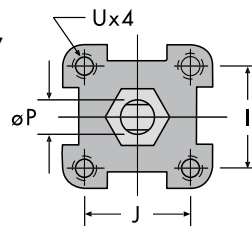

**3" - 4"
Valves**

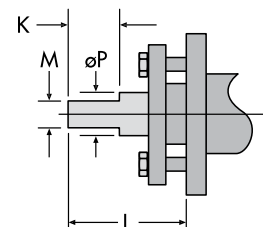
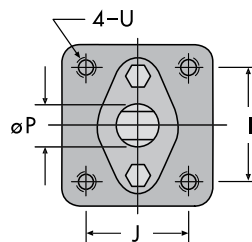

Extended end connections allow for welding the valve in the piping system without valve disassembly.

Ordering Information

Item	Selection	Code
Body Style	Standard Bore Port	SP
	Full Bore Port	FP
Body Material	Stainless Steel (A351 Gr CF8M)	3
	Carbon Steel (A216 Gr WCB)	2
End Connection	Threaded (NPT)	1
	Socket Weld	2
	Extended Socket Weld	2E
	Butt Weld	3
	Extended Butt Weld	3E
	ASME Flanged - CL 600	4C
Valve Size	1/4" = 01, 3/8" = 02, 1/2" = 03, 3/4" = 04	
	1" = 05, 1 1/4" = 06, 1 1/2" = 07, 2" = 08	
	2 1/2" = 09, 3" = 10, 4" = 11	
Ball and Stem	316 Stainless Steel	3
Seat	RPTFE	R
	PEEK	P
	Tek Fil (Carbon Graphite/TFM)	K
	TFM	J
	Virgin PTFE	T
	Stainless Steel Filled PTFE	S
	UHMWPE	U
	Stellite - Metal	M
	Cavity Fillers (PTFE is Standard)	CF
Stem Seal	Graphite	G
Operator	Manual Locking Handle	L
	Oval Locking Handle	OL
	Double Acting Actuator	DA
	Spring Return Actuator	SR
	Electric Actuator	EL
	Gear Operator	G
Options	Special Feature	SF

Ordering Example:

Body Style	Material (316)	Connection (NPT)	Size (1")	Ball/Stem (316)	Seat (PEEK)	Stem Seal (Graphite)	Operator (Handle)
FP	3	1	05	3	P	G	L

Tek-Fil® is a registered trademark of Flow-Tek, Inc.
Stellite® is a registered trademark of Cabot Corporation.

3 Piece Valve Body Design

The 3 piece body design of the Triad Series offers many advantages, including installation flexibility, elimination of the need for two sets of flanges, and ease of in line and out of line servicing. These time saving features are beneficial for process industries, automated valves and welded piping systems by reducing costly downtime. During maintenance, the actuator and accessories can remain mounted on the valve body. The entire valve and actuator assembly is easily reinstalled with no need for recalibration of the unit.

In Line Servicing To perform in line maintenance, remove the body bolts on opposing sides of the center body, loosen the 2 bolts at the top of the valve and swing the body up. The valve can swing to the left or right depending on which bolts are removed. All body components can be serviced in this position without disturbing the piping system.

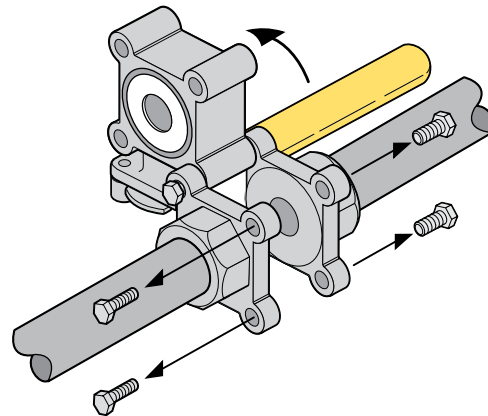

Out of Line Servicing For complete removal of valve from the line, remove all body bolts, then lift the valve body out of the pipeline. The removed body can then be serviced or replaced, then reinstalled without needing to realign the end connections or the piping system.



Flow-Tek®

A Subsidiary of BRAY INTERNATIONAL, Inc.
8323 N. Eldridge Pkwy #100 Houston, Texas 77041
832.912.2300 Fax: 832.912.2301
www.flow-tek.com

All statements, technical information, and recommendations in this bulletin are for general use only. Consult Flow-Tek representatives or factory for the specific requirements and material selection for your intended application. The right to change or modify product design or product without prior notice is reserved.

Flow-Tek® is a registered trademark of Flow-Tek, Inc.
© 2012 Flow-Tek, Inc.
F-2300_EN_Triad_2013-03