

Instruction Manual

CVS Series H-900, H-1500 and H-2500 Design Valve Bodies

Contents

Contained in this manual are installation instructions, maintenance procedures and parts information for the CVS Series H-900, H-1500 and H-2500 Design Valve Bodies. Refer to the appropriate manuals for instructions for the accompanying actuator and additional accessories.

Trained or experienced personnel should carry out operation and installation of all pressure equipment. If you have any questions regarding the equipment, contact your CVS Controls representative. A serial number identifies each CVS Series H valve and is stamped on the valve body. Please reference this number when communicating with your CVS Controls representative.

Applications and Features

The CVS Series H Control Valve provides excellent pressure and flow control on steam, gasses and various liquid applications.

The CVS Design H2D valve is a single port, globe body with cage guiding, and balanced valve plug with push down to close action. Suitable for general applications where tight shutoff is not required.

The CVS Design H5T valve is a single port, globe body with cage guiding, balanced valve plug, metal seat and pressure assisted spring seal to provide a seal between the valve plug and cage. Suitable for applications which require low leakage rates.



Figure 1: Typical CVS Series H Design Body with Trim and Seals

Sour Service Capability

Optional NACE MRO175/ISO 15156-2009

Flow Direction:

For standard cages the flow direction is flow-down.

Flow Characteristics:

Available flow characteristics are quick-opening and equal percentage.

End connections are ASME Class 900 through 2500, with raised face, ring type joint, or flanged end connections as per ASME B16.34-latest edition.

Available in LCC, WCB, CF8M, CF3M and WCC body materials. Other materials available upon request.

Refer to Table 1 for additional specifications.

3900 – 101 Street
Edmonton, Alberta, Canada
T6E 0A5
Office: (780) 437-3055
Fax: (780) 436-5461

CVS
Controls Ltd.

Website: www.cvs-controls.com E-Mail: info@cvs-controls.com

205, 2323 – 32 Avenue NE
Calgary, Alberta, Canada
T2E 6Z3
Office: (403) 250-1416
Fax: (403) 291-9487

Table 1: Specifications

End Connections, Styles and Ratings	Raised Face and Ring Type Joint	ANSI Class H-900, H-1500 to H-2500 per ANSI B16.34-1996 rating.									
	Butt Weld Ends	All schedules compatible with body rating per ANSI B16.34-1996.									
Shutoff Classifications	FC170-2-1998, See Table 2										
Flow Characteristics	Quick Opening, Equal Percentage										
Flow Direction	Flow Down										
Approximate Weight (Valve Body Assembly and Bonnet)	Body Size (in)	ANSI Class H-900 & H-1500						ANSI Class H-2500			
		BWE		Class H-900 FLG		Class H-1500 FLG		BWE		FLG	
		lb	kg	lb	kg	lb	kg	lb	kg	lb	kg
		3	4	365	166	465	211	485	220	522	234
	4	510	232	620	282	680	309	607	275	800	363

Table 2: Shutoff Classifications

Trim Configuration	Port Sizes In. (mm)	ANSI* Shutoff Class	Leakage	Test
ED	2-7/8" (73 mm) and smaller	II (Standard) III (Optional)	0.5% of rated valve capacity	Air at 50 psid (3.4 bar, differential)
	3-7/16" (87.3 mm) and smaller	III (Standard)	0.1% of rated valve capacity	Air at 50 psid (3.4 bar, differential)
ET	All	IV (Standard)	0.01% of rated valve capacity	Air at 50 psid (3.4 bar, differential)
		V (Optional)	5x10 ⁻⁴ ml/minute / inch port diameter / psid (5x10 ⁻¹² m ³ /second / mm of port diameter / bar differential)	Water at maximum service ΔP

* In accordance with FC170-2-1998
 Note: Above values for normal flow directions. Values also apply to Design ED up to 100 psid in the reverse flow direction. Contact your CVS Controls representative for reverse flow applications using the Design ET.

Installation

These valves should not be installed in systems that exceed the ANSI specified temperature and pressure ratings. Inspect the valves for shipping, damage and foreign debris when uncrating.

Be sure to use proper hoists with chains or slings when uncrating and handling these valves. Refer to Table 1 for valve body weights.

1. Ensure the pipe is free from welding slag, chips and other debris by blowing out the line prior to installation.
2. Install approved gaskets between the valve body and the pipeline flanges. For butt weld ends on the CVS Design ET trim configuration, remove gaskets and seal rings prior to welding the body into the pipeline.
3. For continuous service applications, CVS Controls recommends a standard three-valve maintenance bypass be installed. This allows isolation of the valve body without shutting down the pipeline system.

4. The valve should be positioned on the line so the flow direction indicator corresponds to the direction of flow in the pipeline.

Note: The effectiveness of the pressure-energized seal will be compromised if return flow exists where the downstream pressure exceeds upstream pressure. The result could be leakage or damage to the seal.

5. The valve body should be positioned with the actuator vertically above it. It is possible to position the valve with an orientation below vertical with support supplied for the actuator. Support for the actuator is required if there is excessive vibration in the line, or if the valve body is positioned more than 45 degrees off vertical.

Parts Reference

Body Parts (Figures 2 & 3)

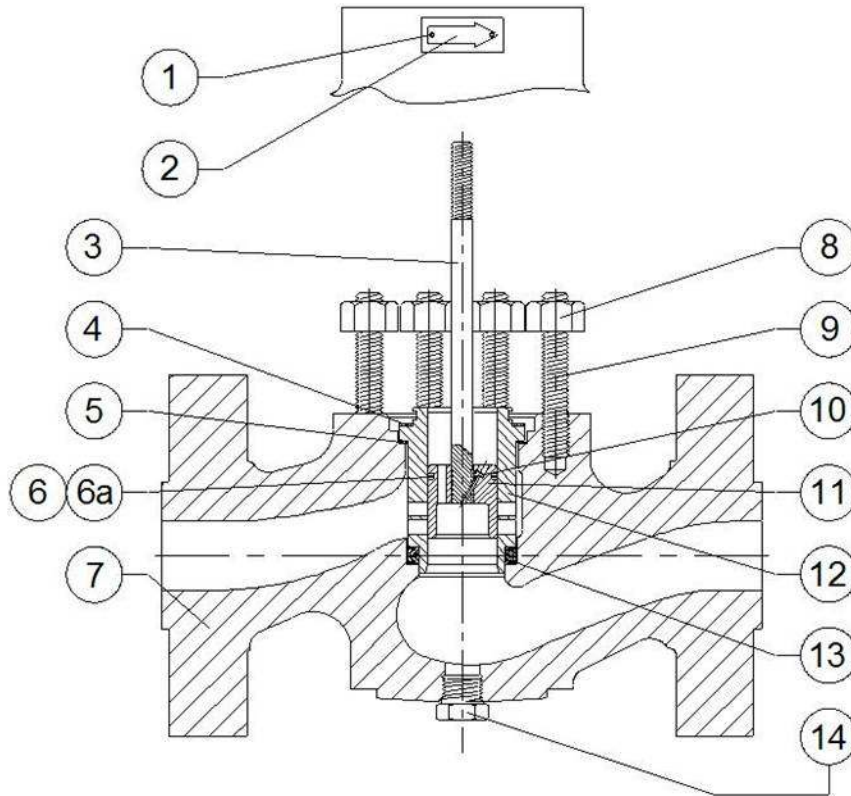

Key	Description
1	Drive Screws
2	Flow Arrow
3	Valve Stem
4	Bonnet Gasket
5	Cage Gasket
6	Inner Piston Ring
6a	Outer Piston Ring
6b	Seal Ring
7	Body
8	Hex Nuts
9	Stud Bolts
10	Groove Pin
11	Valve Plug
12	Cage
13	O-Ring Retainer
14	Pipe Plug (Optional)
15	Retaining Ring
16	Backup Ring

Figure 2: CVS H-900, H-1500 and H-2500 Valve Body Showing Design ED Trim

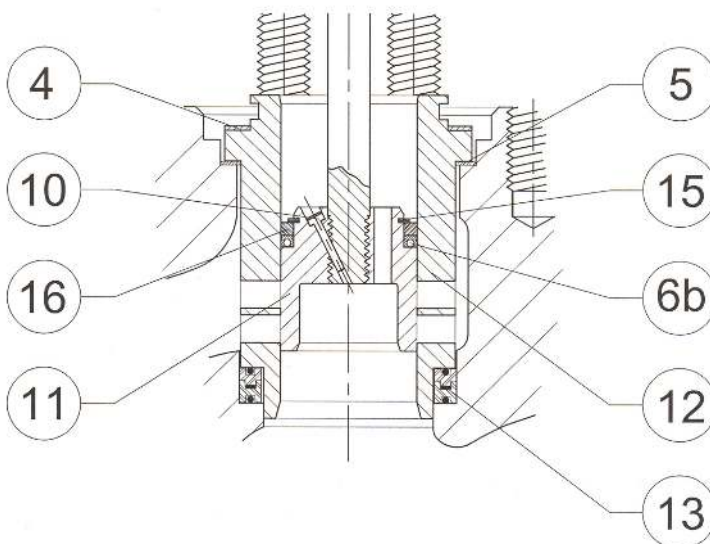

Bonnet Parts (Figure 4)

Key	Description
17	Bonnet
18	Packing Flange
19	Stud Bolts
20	Hex Nuts
21	Packing Set
22	Packing Spring
23	Special Washer
24	Packing Box Ring
25	Felt Wiper
26	Packing Follower
27	Pipe Plug
28	Locknut

Bonnet Parts Not Shown

Key	Description
29	Individual Packing Rings
30	Individual Packing Rings
31	Pipe Nipple for Lubricator Isolating Valve
32	Lubricator / Isolating Valve or Lubricator

Figure 3: CVS H-900, H-1500 and H-2500 Valve Body Showing Design ET Trim

Maintenance

Internal valve components are subject to normal deterioration and must be inspected and replaced as required. The necessity of inspections and replacement of parts will depend on the severity of service conditions. Inspections and maintenance must be carried out on a regularly scheduled basis.

Before beginning any maintenance, it is important to isolate the control valve and release all pressure contained in the valve body and the actuator.

Packing Replacement

These instructions refer to the replacement of single or double TFE V-Ring, Garlock and Grafoil packing. Key numbers refer to Figures 2, 3 and 4.

1. Release all loading pressure in the actuator and remove control lines.
2. Remove the cap screws from the stem connector and detach the halves of the stem connector.
3. Unscrew the yoke locknut (Figure 4, Key 28) and separate the actuator from the bonnet (Figure 4, Key 17).
4. Remove the hex nuts (Figure 2, Key 8) and lift the bonnet (Figure 4, Key 17) and valve plug and stem assembly from the valve body (Figure 2, Key 7). Set those components on a clean surface and protect the gasket sealing serrations in the bottom of the bonnet. These serrations are essential for a tight seal between the body and bonnet during reassembly.
5. Remove the bonnet gasket (Figure 2 and 3, Key 4).
6. Loosen the packing flange nuts (Figure 4, Key 20) so the packing becomes loose around the stem.
7. Remove the hex nuts from the valve plug stem (Figure 2, Key 3) and pull the valve plug and stem assembly out of the bonnet. Place this assembly on a protective surface.
8. Remove the hex nuts (Figure 4, Key 20), the packing flange (Figure 4, Key 18), the packing follower (Figure 4, Key 26) and the felt wiper (Figure 4, Key 25).

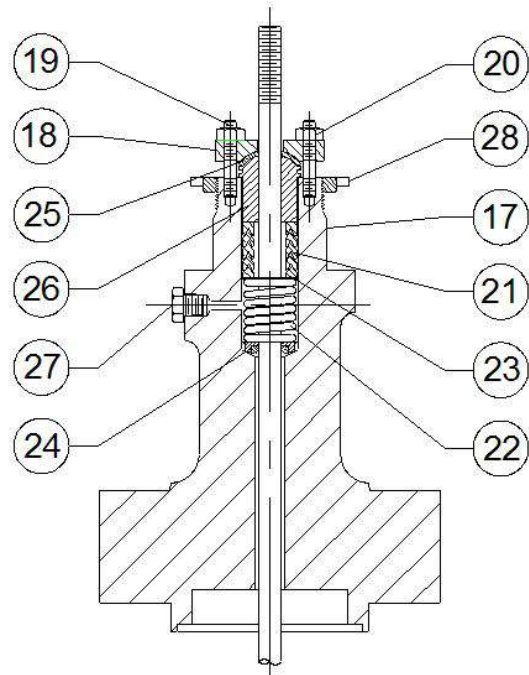

Table 3: Recommended Bonnet Bolt Torque

Body Size (in)	Bonnet Bolt Torque			
	Class H-900 & H-1500		Class H-2500	
	Ft-lb	N m	Ft-lb	N m
3	404	548	404	548
4	540	732	540	732

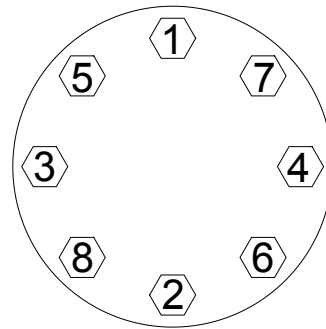

Figure 5: Typical Bolting Pattern

Packing Replacement cont'd

- Use a packing hook to remove the packing parts, or push them toward the top of the bonnet using a small rod. Be careful not to scratch the wall of the packing box.
- Clean the metal packing parts and the packing box, and check the valve stem and packing box surfaces for nicks or scratches. Remove any light scratches with sanding. If damage exists that cannot be sanded out, the valve plug stem and bonnet must be replaced.
- Install a new bonnet gasket (Figures 2 and 3, Key 4) onto the cage (Figures 2 and 3, Key 12).

Note: The valve plug assembly of the ED and ET fit inside the cage with tight tolerances. When installing the valve plug assembly be sure not to damage the piston rings or the seal ring (Figures 2 and 3, Keys 6, 6a, 6b).

When the bonnet is being mounted, the threads of the valve plug stem will slide through the packing box. If the packing has been installed, carefully attach the bonnet to avoid cutting the packing on the stem threads.

- Insert the valve plug assembly in the cage, mounting the bonnet onto the body. Ensure that the leak-off piping (or pipe plug, Figure 4, Key 27) is facing downstream.
- Apply lubricant to the body stud bolts (Figures 2 and 3, Key 9) and the hex nuts (Figures 2 and 3, Key 8). Thread the nuts onto the body stud bolts using good bolting practices. Refer to Table 3 for proper bolt torques and tighten the nuts in a criss-cross pattern (See Figure 5). When the control valve assembly reaches operating temperature, repeat the procedure. Proper tightening of the bonnet nuts ensures a positive sealing of the cage seals and the spring seal.

Note: Repeating the bolting pattern may be necessary since tightening one nut may loosen an adjacent nut. The body-to-bonnet seal will be complete when none of the nuts will turn at the recommended torque.

- Refer to Figure 4 and arrange the packing parts as outlined. Slide the new packing carefully over the valve plug stem, and ensure that the packing parts are not damaged by the threads of the valve plug stem.
- Reinstall the packing flange and hex nuts (Keys 18 and 20). Tighten the hex nuts until the shoulder of the packing follower (Key 26) is snug against the packing box.
- Mount the actuator onto the valve body assembly and reconnect the actuator and valve stem referring to procedures in the appropriate actuator manual.

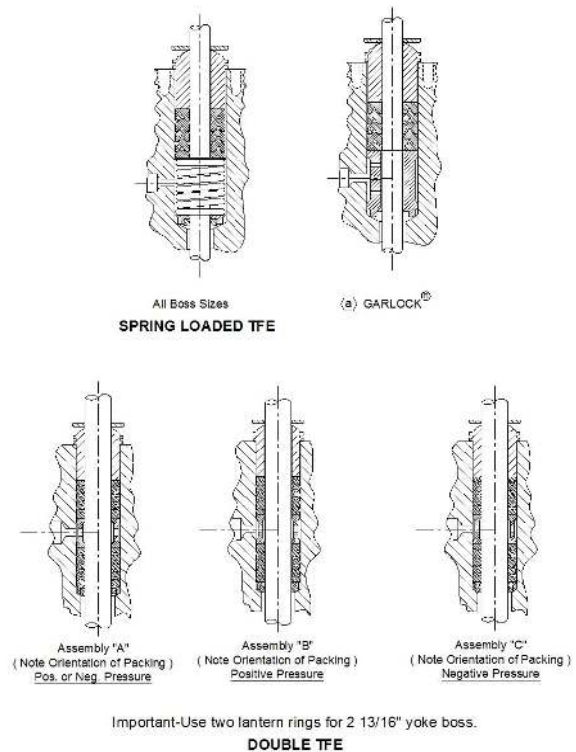

Figure 6: Packing Arrangements
See Table 4 for Recommended Torque Values

GARLOCK is a registered trademark for packings, seals, gaskets and other products of Garlock.

Trim Maintenance

Refer to this section for instructions regarding disassembly, replacement of valve plug parts, grinding metal seats and assembly of the valve body as required when replacing trim.

During trim maintenance, always replace the gaskets (Keys 4 and 5). With Design ET trim, also replace the seal ring (Key 6b).

Disassembly

1. Complete steps 1 through 6 in the section titled "Packing Replacement".
2. Lift out the cage (Key 12) and cage gaskets (Key 5). If the cage is stuck, insert a blunt tool into the groove around the top of the cage and pry it free.
3. Complete the required maintenance following instructions in the sections "Replacing Valve Plug Parts", "Lapping Metal Seats", or "Assembly" as appropriate.

Replacing Valve Plug Parts

These instructions are for the TFE V-ring packing. Grafoil and Garlock packing is also available and is supplied with complete replacement instructions.

Note: Do not use an old stem with a new valve plug. Using an old stem would require drilling a new groove pin hole, and doing so would weaken the stem.

1. To replace the valve plug stem (Key 3), begin by driving out the groove pin (Key 10) and removing the stem.
2. Insert the new stem, threading it completely into the valve plug (Key 11). Ensure that all threads are engaged.

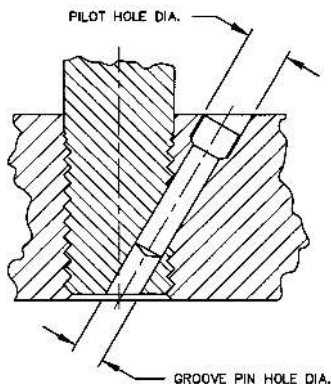

3. Refer to Table 4 and drill the proper sized groove pin hole through the stem. Insert the groove pin which fastens the assembly together.
4. To replace the valve plug rings follow the instructions appropriate for your trim configuration:
 - 4.1. **Design ED Trim:** remove both piston rings (Keys 6 and 6a) and replace them if they show damage or uneven wear. Install the rings while avoiding excessive bending. Slip the ring with a straight cut over the valve plug and insert the ring into the groove. The ring with the stepped cut slips over the valve plug. Rotate the rings in the groove until the two cuts are in opposite sides of the groove.
 - 4.2. **Design ET Trim:** Raise the end of the retaining ring (Key 15) using a screwdriver. Rotate the plug and lift the ring out and up. Avoid scratching any plug or ring surfaces. Remove the metal backup ring (Key 16) and TFE seal ring (Key 6b). Refer to Figure 6 and install the seal ring for proper flow direction. Install the metal backup ring. Insert one end of the retaining ring (Key 15) into the groove of the valve plug. While turning the plug, press the ring into the groove, being careful not to scratch the valve plug and retaining ring.
5. Continue with procedures for "Lapping Metal Seats" or "Assembly" as required.

Table 4: Drill Size for Groove Pins

Port Size		Valve Stem Connection		Drill Size	
In.	mm	In.	mm	In.	mm
1-5/16	33.3	1/2	12.7	3/32	2.4
		1/2	12.7	1/8	3.2
1-7/8	47.6	3/4	19.1	1/8	3.2
		1/2	12.7	1/8	3.2
2-5/16	58.7	3/4	19.1	3/16	4.8
		1	25.4	3/16	4.8
		1/2	12.7	1/8	3.2
2-7/8	73.0	3/4	19.1	3/16	4.8
		1	25.4	1/4	6.4
		3/4	19.1	3/16	4.8
3-7/16	87.3	1	25.4	1/4	6.4

Lapping Metal Seats

While some leakage is expected with any metal-to-metal seating in a valve body, excessive leakage can be improved by lapping or grinding the valve plug and seat ring. Deep nicks should be machined out. A good quality commercial-grade lapping compound should be used.

Apply lapping compound to the valve plug seating surface. During lapping, the bonnet must be bolted to the body and the gaskets (old gaskets may be used) in place in order to keep the valve plug in line with the seat ring. A simple grinding tool can be made using a piece of strap iron fastened to the valve plug stem with nuts.

Rotate the handle in opposite directions to lap the seating surfaces.

After grinding, remove the bonnet and clean the seating surfaces. Test for proper shutoff and repeat the process if necessary.

Assembly

Caution must be used when working around the sealing surfaces. Any nicks or scratches will compromise the sealing ability. Prior to installing the seals, the sealing surface should be wiped with a clean cloth.

1. Install the o-ring retainer (Key 13) into the valve body.
2. Install the cage gasket (Key 5).
3. Install the cage (Key 12) into the valve body.
4. Proceed with steps 11 through 16 of the section titled "Packing Replacement".

Parts Ordering

Valves manufactured by CVS Controls have individual serial numbers, found on the valve nameplate. Please refer to that number when ordering parts or contacting your CVS Controls Sales Representative. Individual part numbers are listed in the following section. Please include these numbers when ordering replacement parts.

CVS Series H-900, H-1500 and H-2500 Design Valve Bodies

Key	Description	Part Number	
1	Drive Screws, SST (2 req'd)	CVS1A368228982	
2	Flow Arrow, SST	CVS1V106038982	
3	Valve Stem	See Following Tables	
4	Bonnet Gasket*	Class H-900 and Class H-1500	3" Body Size CVS10A4154X012
		Class H-2500	4" Body Size CVS10A5457X012
			3" Body Size CVS10A4107X012
		4" Body Size CVS10A4154X012	
5	Cage Gasket	Class H-900 and Class H-1500	3" Body Size CVS10A4155X012
		Class H-2500	4" Body Size CVS10A5458X012
			3" Body Size CVS10A4108X012
		4" Body Size CVS10A4155X012	
6	Piston Ring or Seal Ring	See Following Tables	
7	Body	See Following Tables	
8	Hex Nuts	See Following Tables	
9	Stud Bolts	See Following Tables	
10	Groove Pin	See Following Tables	
11	Valve Plug	See Following Tables	
12	Cage	See Following Tables	
13	O-Ring Retainer	See Following Tables	
14	Pipe Plug (Optional)	Steel for LCC and WCB Bodies CVS1A771528992	
		316SST for CF8M Bodies CVS1A771535072	
15	Retaining Ring	See Following Tables	
16	Backup Ring	See Following Tables	
17	Bonnet	See Following Tables	
18	Packing Flange	2-13/16" Boss, 1/2" Stem	Steel (Standard) CVS1E944223072
		3-9/16" Boss, 3/4" Stem	316 SST CVS1F380335072
			Steel (Standard) CVS1E944823072
		316 SST CVS1F380435072	
19	Stud Bolts (2 Req'd)	2-13/16" Boss, 1/2" Stem	Steel (Standard) CVS1E944431032
		3-9/16" Boss, 3/4" Stem	316 SST CVS1E944435222
			Steel (Standard) CVS1E944931032
		316 SST CVS1E944935222	
20	Hex Nuts (2 Req'd)	2-13/16" Boss, 1/2" Stem	Steel (Standard) CVS1E944524112
		3-9/16" Boss, 3/4" Stem	316 SST CVS1E944535252
			Steel (Standard) CVS1E944624112
		316 SST CVS1E944635252	
21	Packing Set	See Following Tables	
22	Lantern Ring or Spring	See Following Tables	
23	Special Washer	See Following Tables	
24	Packing Box Ring	See Following Tables	
25	Felt Wiper	See Following Tables	
26	Packing Follower	See Following Tables	
27	Pipe Plug	Steel, for LCC and LCB Bodies CVS1A767524662	
		316SST for CF8M Bodies CVS1A767535072	
28	Locknut, Steel	2-13/16" Boss, 1/2" Stem CVS1E807423062	
		3-9/16" Boss, 3/4" Stem CVS1E832723062	
29	Packing Ring	See Following Tables	
30	Packing Ring	See Following Tables	
31	Pipe Nipple for Lubricator Isolating Valve	For LCC Bonnets CVS1D239726232	
		For all other Bonnets CVS1B292738332	
32	Lubricator / Isolating Valve	CVSAJ5428000A2	
		Lubricator CVS0V0873000A2	

* Recommended Spare Part

Key 3: Valve Stem*

ANSI Body Rating	Body Size (In)	Stem Size		Port Size		Part Number
		In	mm	In	mm	
Class H-900 and Class H-1500	3	1/2	12.7	B	B	CVS1K587435162
		3/4	19.1	1-7/8	47.6	CVS1U444635162
				2-7/8	73.0	CVS1K588035162
	4	3/4	19.1	B	B	CVS1U444635162
Class H-2500	3	1/2	12.7	B	B	CVS1K587235162
		3/4	19.1	2-5/16	58.7	CVS1K588035162
	4	3/4	19.1	1-7/8	47.6	CVS1U444635162
				2-7/8	73.0	CVS1K588035162

B: Available in both port sizes (Full and Restricted)

Key 6: Piston Ring (Design ED) or Seal Ring (Design ET)*

ANSI Body Rating	Body Size (In)	Port Size		Design ED Piston Ring	Design ET Seal Ring	
		In	mm	Alloy #25 and 17-4 PH SST 450°F to 800°F (232°C to 427°C)	Spring-Loaded FEP -425°F to -100°F (-253°C to -73°C)	Spring-Loaded TFE -100°F to 450°F (-73°C to 232°C)
Class H-900 and Class H-1500	3	1-7/8	47.6	CVS10A4214X012	CVS10A4216X022	CVS10A4216X012
		2-7/8	73.0	CVS10A4213X012	CVS10A4215X022	CVS10A4215X012
	4	2-5/16	58.7	CVS10A4204X012	CVS10A4206X022	CVS10A4206X012
		3-7/16	80.6	CVS10A5348X012	CVS10A5351X012	CVS10A5351X022
Class H-2500	3	1-5/16	33.3	CVS10A4205X012	CVS10A4207X022	CVS10A4207X012
		2-5/16	58.7	CVS10A4204X012	CVS10A4206X022	CVS10A4206X012
	4	1-7/8	47.6	CVS10A4214X012	CVS10A4216X022	CVS10A4216X012
		2-7/8	73.0	CVS10A4213X012	CVS10A4215X022	CVS10A4215X012

Key 7: Body LCC Steel

ANSI Body Rating	End Connections		Body Size, Inches Without Drain Plug Tapping	
			3	4
			Class H-900 and Class H-1500	900 lb
RTJ	CVS30A5291X032	CVS30A5308X032		
1500 lb	RF	CVS30A5289X032		CVS30A5306X032
	RTJ	CVS30A5293X032		CVS30A5310X032
Butt Weld	80	CVS30A5295X032		CVS30A5312X032
	160	CVS30A5297X032		CVS30A5314X032
Class H-2500	2500 lb	RF	CVS30A4065X032	CVS30A4110X032
		RTJ	CVS30A4067X032	CVS30A4112X032
	Butt Weld	80	CVS30A4069X032	CVS30A4114X032
		XXS	CVS30A4071X032	CVS30A4116X032

WCB Steel

ANSI Body Rating	End Connections		Body Size, Inches Without Drain Plug Tapping	
			3	4
			Class H-900 and Class H-1500	900 lb
RTJ	CVS30A5291X012	CVS30A5308X012		
1500 lb	RF	CVS30A5289X012		CVS30A5306X012
	RTJ	CVS30A5293X012		CVS30A5310X012
Butt Weld	80	CVS30A5295X012		CVS30A5312X012
	160	CVS30A5297X012		CVS30A5314X012
Class H-2500	2500 lb	RF	CVS30A4065X012	CVS30A4110X012
		RTJ	CVS30A4067X012	CVS30A4112X012
	Butt Weld	80	CVS30A4069X012	CVS30A4114X012
		XXS	CVS30A4071X012	CVS30A4116X012

* Recommended Spare Part

Key 7: Body cont'd

CF8M

ANSI Body Rating	End Connections		Body Size, Inches	
			Without Drain Plug Tapping	
			3	4
Class H-900 and Class H-1500	900 lb	RF	CVS30A5287X052	CVS30A5304X052
		RTJ	CVS30A5291X052	CVS30A5308X052
	1500 lb	RF	CVS30A5289X052	CVS30A5306X052
		RTJ	CVS30A5293X052	CVS30A5310X052
	Butt Weld	80	CVS30A5295X052	CVS30A5312X052
		160	CVS30A5297X052	CVS30A5314X052
Class H-2500	2500 lb	RF	CVS30A4065X052	CVS30A4110X052
		RTJ	CVS30A4067X052	CVS30A4112X052
	Butt Weld	80	CVS30A4069X052	CVS30A4114X052
		XXS	CVS30A4071X052	CVS30A4116X052

Key 8: Hex Nuts

Key 9: Stud Bolts

Valve Body Material	Temperature Capabilities		Class H-900 and Class H-1500 Body			
			3" Body		4" Body	
			Key 8: Hex Nuts (8 req'd)	Key 9: Stud Bolts (8 req'd)	Key 8: Hex Nuts (8 req'd)	Key 9: Stud Bolts (8 req'd)
	(°F)	(°C)				
WCB Steel	-20 to 800	-29 to 427	CVS1A440924072	CVS10A5564X012	CVS1A445224072	CVS10A5565X012
LCC Steel	-50 to 650	-45 to 343	CVS1A440924072	CVS10A5564X012	CVS1A445224072	CVS10A5565X012
CF8M	-425 to -325	-254 to -198	CVS1A4409X0012	CVS10A5564X062	CVS1A4452X0022	CVS10A5565X062
	-325 to -50	-198 to -46	CVS1A440935252	CVS10A5564X042	CVS1A445235252	CVS10A5565X042
	-50 to 450 ¹	-46 to 232	CVS1A440924072	CVS10A5564X012	CVS1A445224072	CVS10A5565X012
	-50 to 450 ²	-46 to 232	CVS1A440935252	CVS10A5564X042	CVS1A445235252	CVS10A5565X042
	450 to 1000	232 to 538	CVS1A440935252	CVS10A5564X042	CVS1A445235252	CVS10A5565X042
	1000 to 1100	538 to 593	CVS1A440935252	CVS10A5564X032	CVS1A445235252	CVS10A5565X032
Valve Body Material	Temperature Capabilities		Class H-2500 Body			
			3" Body		4" Body	
			Key 8: Hex Nuts (8 req'd)	Key 9: Stud Bolts (8 req'd)	Key 8: Hex Nuts (8 req'd)	Key 9: Stud Bolts (8 req'd)
	(°F)	(°C)				
WCB Steel	-20 to 300	-29 to 149	CVS1A440924072	CVS1A365631012	CVS1A445224072	CVS1D945231012
LCC Steel	-50 to 650	-45 to 343	CVS1A440924072	CVS10A5563X012	CVS1A445224072	CVS10A4221X012
CF8M	-425 to -325	-254 to -198	CVS1A4409X0012	CVS1A3656X0022	CVS1A4452X0022	CVS1D9452X0032
	-325 to -50	-198 to -46	CVS1A440935252	CVS1A365635222	CVS1A445235252	CVS1D945235222
	-50 to 450 ¹	-46 to 232	CVS1A440924072	CVS1A365631012	CVS1A445224072	CVS1D945231012
	-50 to 450 ²	-46 to 232	CVS1A440935252	CVS1A365635222	CVS1A445235252	CVS1D945235222
	450 to 1000	232 to 538	CVS1A440935252	CVS1A365635222	CVS1A445235252	CVS1D945235222
	1000 to 1050	538 to 566	CVS1A440935252	CVS1A3656X0012	CVS1A445235252	CVS1D9452X0022

¹ Steel (B7) Bolting

² Strain Hardened SST (B8M) Bolting

Key 10: Groove Pin, 316 SST*

Port Size		Valve Stem Connection		ED, ET
In	mm	In	mm	
1-5/16	33.3	1/2	12.7	CVS1V322635072
		1/2	12.7	CVS1V322735072
1-7/8	47.6	3/4	19.1	CVS2V322735072
		1/2	12.7	CVS1V322735072
		3/4	19.1	CVS1V326035072
2-5/16	58.7	1	25.4	CVS1V326035072
		1/2	12.7	CVS1V322735072
		3/4	19.1	CVS1V326035072
2-7/8	73.0	1	25.4	CVS1V334035072

Key 11: Valve Plug*

ANSI Body Rating	Body Size (In)	Port Size		Valve Stem Connection		ED	ET
		In.	mm	In.	mm	316 SST	
Class H-900 and H-1500	3	1-7/8	47.6	1/2	12.7	CVS20A4148X012	CVS20A4150X012
				3/4	19.1	CVS20A9355X012	CVS20A9357X012
		2-7/8	73.0	1/2	12.7	CVS20A9531X012	CVS20A9533X012
				3/4	19.1	CVS20A4140X012	CVS20A4144X012
	4	2-5/16	58.7	3/4	19.1	CVS20A4094X012	CVS20A4098X012
				3-7/16	87.3	3/4	19.1
Class H-2500	3	1-5/16	33.3	1/2	12.7	CVS20A9363X012	CVS20A9365X012
				1/2	12.7	CVS20A4093X012	CVS20A4097X012
		2-5/16	58.7	3/4	19.1	CVS20A4094X012	CVS20A4098X012
				3/4	19.1	CVS20A4140X012	CVS20A4144X012
	4	1-7/8	47.6	3/4	19.1	CVS20A9355X012	CVS20A9357X012
				2-7/8	73.0	3/4	19.1

Key 12: Cage

ANSI Body Rating	Body Size (In)	Port Size		Equal Percentage		Linear	
		In	mm	17-4 PH SST Hardened	316 SST	17-4 PH SST Hardened	316 SST
Class H-900 and H-1500	3	1-7/8	47.6	CVS30A4137X012	CVS30A4138X012	CVS30A4131X012	CVS30A4132X012
		2-7/8	73.0	CVS30A4134X012	CVS30A4135X012	CVS30A4128X012	CVS30A4129X012
	4	2-5/16	58.7	CVS30A5335X012	CVS30A5336X012	CVS30A5329X012	CVS30A5330X012
		3-7/16	87.3	CVS30A5334X012	CVS30A5333X012	CVS30A5326X012	CVS30A5327X012
Class H-2500	3	1-5/16	33.3	CVS30A4091X012	CVS30A4092X012	CVS30A4086X012	CVS30A4087X012
		2-5/16	58.7	CVS30A4088X012	CVS30A4089X012	CVS30A4083X012	CVS30A4084X012
	4	1-7/8	47.6	CVS30A4137X012	CVS30A4138X012	CVS30A4131X012	CVS30A4132X012
		2-7/8	73.0	CVS30A4134X012	CVS30A4135X012	CVS30A4128X012	CVS30A4129X012

Key 13: O-Ring Retainer *

ANSI Body Rating	Body Size (In)	Upper Retainer 316 SS	Lower Retainer 316 SS	Seal Kits	
				Viton*	HSN
Class H-900 and H-1500	3	CVS13A0295X012	CVS13A0297X012	CVS3H1500-SK-V	CVS3H1500-SK-H
	4	CVS13A0296X012	CVS13A0298X012	CVS4H1500-SK-V	CVS4H1500-SK-H
Class H-2500	3	CVS15A9173X012	CVS15A0295X012	CVS3H2500-SK-V	CVS3H2500-SK-H
	4	CVS15A9174X012	CVS15A0296X012	CVS4H2500-SK-V	CVS3H2500-SK-H

* Viton is a registered trademark of DuPont Dow Elastomers

Key 15: Retaining Ring

ANSI Body Rating	Body Size (In)	Full Sized Trim
Class H-900 and H-1500	3	CVS20A4219X012
	4	CVS10A5350X012
Class H-2500	3	CVS10A4210X012
	4	CVS10A4219X012

Key 16: Backup Ring

ANSI Body Rating	Body Size (In)	Full Sized Trim	
		316 SST	316 SST with Alloy #6
Class H-900 and H-1500	3	CVS20A4217X012	CVS20A4217X022
	4	CVS10A5349X012	CVS10A5349X022
Class H-2500	3	CVS10A4208X012	CVS10A4208X022
	4	CVS10A4217X012	CVS10A4217X022

* Recommended Spare Part

Key 17: Bonnet

ANSI Body Rating	Body Size (In)	Stem Size		WCB	LCC	CF8M
		In	mm			
Class H-900 and H-1500	3	1/2	12.7	CVS30A7504X012	CVS30A7504X032	CVS30A7504X052
	4	3/4	19.1	CVS30A5300X012	CVS30A5300X032	CVS30A5300X052
Class H-2500	3	1/2	12.7	CVS30A4075X012	CVS30A4075X032	CVS30A4075X052
	4	3/4	19.1	CVS30A4074X012	CVS30A4074X032	CVS30A4074X052
		3/4	19.1	CVS30A4119X012	CVS30A4119X032	CVS30A4119X052

Key 21: Packing Set*

Boss Size		Stem Size		Spring-Loaded TFE V-Ring	Double TFE V-Ring (2 req'd)
In	mm	In	mm		
2-13/16	71.4	1/2	12.7	CVS1R290201012	CVS1R290201012
3-9/16	90.5	3/4	19.1	CVS1R290401012	CVS1R290401012

Key 22: Lantern Ring or Spring

Boss Size		Stem Size		Spring Loaded TFE V-Ring		Lantern Ring with Double TFE V-Ring (2 req'd)	
In	mm	In	mm	No. Req'd	Part Number	No. Req'd	Part Number
2-13/16	71.4	1/2	12.7	1	CVS1F125537012	3	CVS1J962335072
3-9/16	90.5	3/4	19.1	1	CVS1F125637012	2	CVSON028435072

Keys 23, 24, 25, 26: Packing Parts

Includes Special Washer, Packing Box Ring, Felt Wiper, Packing Follower

Boss Size		Stem Size		Key 23: Special Washer 316 SST (TFE V-Ring Only)	Key 24: Packing Box Ring		Key 25: Felt Wiper	Key 26: Follower 316 SST
In	mm	In	mm		17-4PH SST	316 SST		
2-13/16	71.4	1/2	12.7	CVS1F125136042	---	CVS1J873235072	CVS1J872706332	CVS1E944335072
3-9/16	90.5	3/4	19.1	CVS1F125036042		CVS1J873335072	CVS1J872806332	CVS1E944735072

Keys 29 and 30: Packing Rings (Set only)

Boss Size		Stem Size		TFE		Grafoil	
In	mm	In	mm	No. Req'd	Part Number	No. Req'd	Part Number
2-13/16	71.4	1/2	12.7	10	CVS1E319001051	3	CVS1V380201652
3-9/16	90.5	3/4	19.1	8	CVS1E319101051	4	CVS1V239601652

* Recommended Spare Part

CVS Controls Ltd. strives for the highest levels of quality and accuracy. The information included in this publication is presented for informational purposes only. CVS Controls Ltd. reserves the right to modify or change, and improve design, process, and specifications without written notice. Under no circumstance is the information contained to be interpreted to be a guarantee/warranty with regard to our products or services, applicability or use. Selection, use and maintenance are the sole responsibility of the end user and purchaser. CVS Controls assumes no liability for the selection use and maintenance of any product.

Printed in Canada
Rev 1 Oct 2013